

# KMD Series Hydraulic swivel joints

Applicable medium	Temperature	Max pressure	Max Rotary Speed
Air	10bar	90°C	300RPM
Hydraulic oil	300bar		



## Product Features

- ▲ Balanced mechanical air seal design, using stainless steel springs to compensate for wear and tear, longer life cycle;
- ▲ The sealing material is a wear-resistant tungsten carbide material imported from Germany to ensure high quality and high pressure resistance;
- ▲ Double bearings, using imported bearings to ensure that the deflection and clearance are in the ideal range at high speeds;
- ▲ The stainless steel shaft is heat-treated and ground to ensure rigidity without deformation for a long time and no eccentric force;
- ▲ A pair of friction pairs are processed by mirror grinding to ensure long life and high pressure resistance.

## Dimension

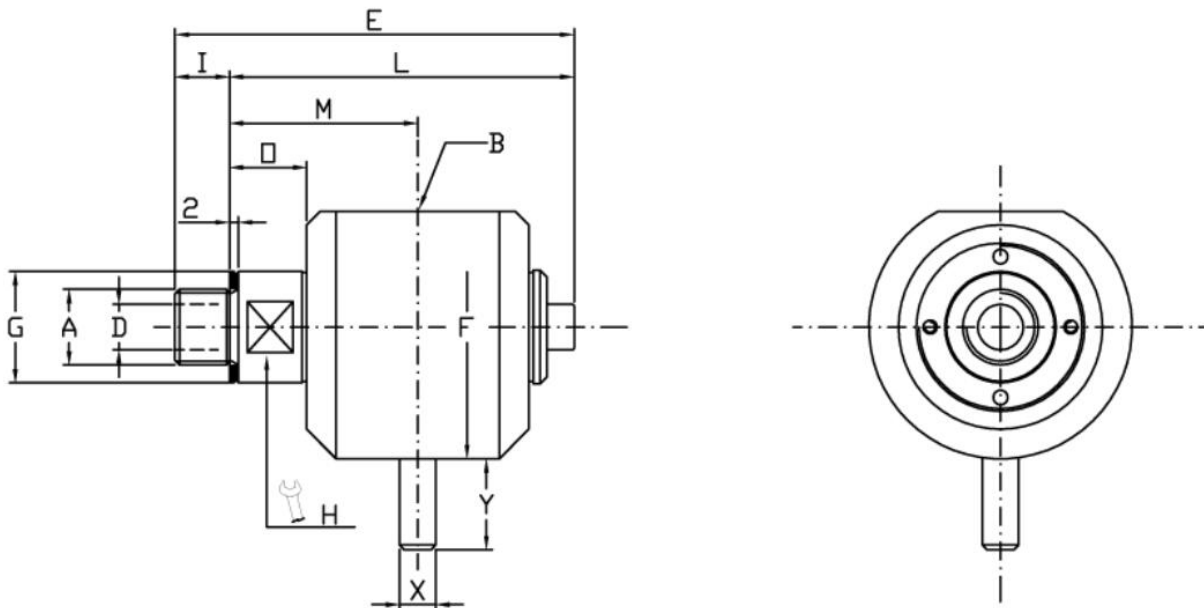

Model Selection table														
Model	A	B	φD	E	φF	φG	H	I	L	M	O	X	Y	Kg
KM108-1000-01R	G1/4"RH	G1/4"	7	77	48	19.5	17	12	65	36	16	8	20	0.4
KM110-1000-01R	G3/8"RH	G3/8"	10	88	58	24.5	22	12	76	41.5	17	8	20	0.5
KM115-1000-01R	G1/2"RH	G1/2"	12	88	58	27.5	24	14	74	39.5	15	8	20	0.5
KM120-1000-01R	G3/4"RH	G3/4"	17.5	119	78	34.5	28	16	103	56	22	8	20	0.3

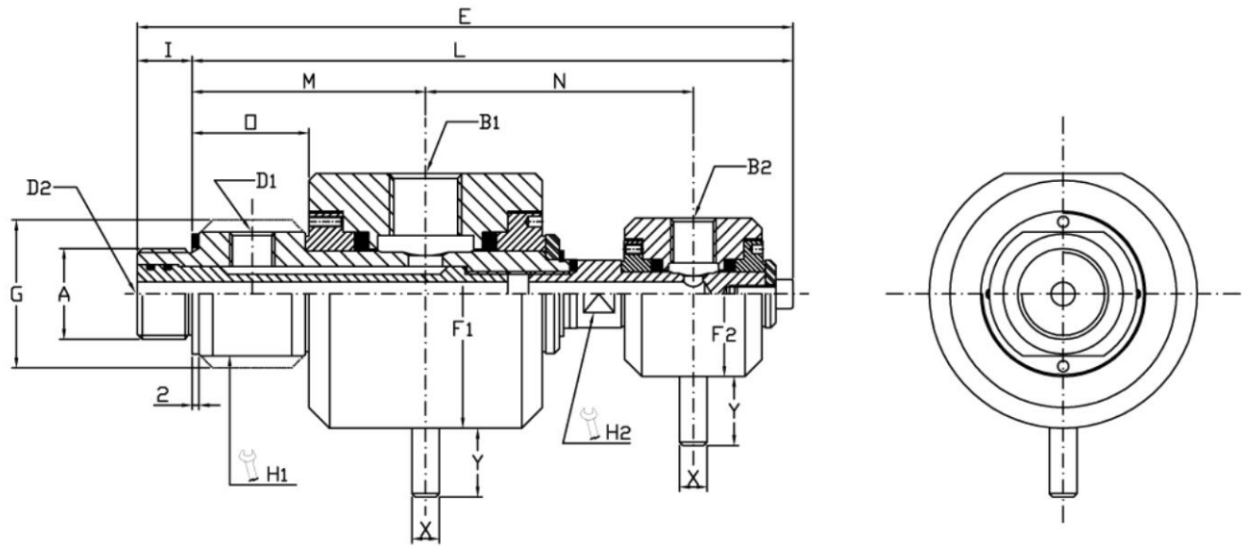

Model Selection table

Model	A	B1	B2	D1	$\phi D2$	E	$\phi F1$	$\phi F2$	$\phi G$	H1	H2	I	L	M	N	O	X	Y	Kg
KM120-1002-11R	G3/4"RH	G1/2"	G1/4"	G1/4"	7	191	78	48	43	38	17	16	175	68	78	34	8	20	1.3