

MB250F Series

Industry Bus Slip Rings(high speed transmission)

MB250F series is standard series integral and precise industry bus slip ring, with OD 86mm, without through bore,rotor flange installation,can support Profibus,EtherCAT, CanBUS, CANOPEN, DeviceNET, CC-LINK, ProfiNET, etc.

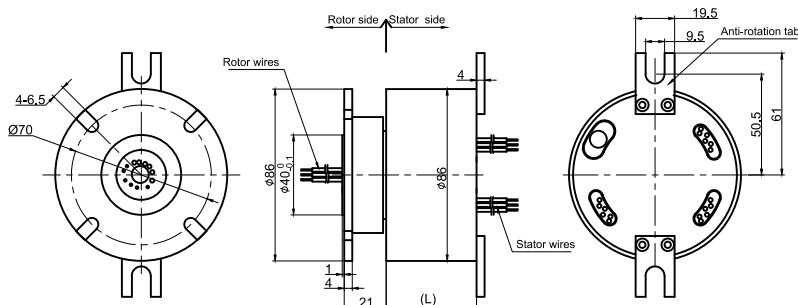
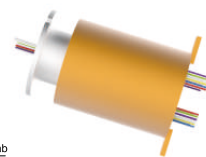

Part# Explanation

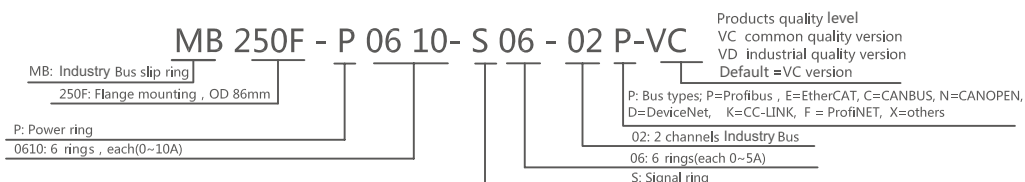

Part# List

Part#	10A	Signal or 5A	Industrial Bus	Length (mm)	Part#	10A	Signal or 5A	Industrial Bus	Length (mm)
MB250F-01P	0	0	Profibus ×1	45.2	MB250F-01E	0	0	EtherCAT ×1	45.2
MB250F-P0610-01P	6	0	Profibus ×1	65.6	MB250F-P0610-01E	6	0	EtherCAT ×1	65.6
MB250F-P1210-01P	12	0	Profibus ×1	86	MB250F-P1210-01E	12	0	EtherCAT ×1	86
MB250F-P0610-S06-01P	6	6	Profibus ×1	86	MB250F-P0610-S06-01E	6	6	EtherCAT ×1	86
MB250F-S12-01P	0	12	Profibus ×1	86	MB250F-S12-01E	0	12	EtherCAT ×1	86
MB250F-P1810-01P	18	0	Profibus ×1	106.4	MB250F-P1810-01E	18	0	EtherCAT ×1	106.4
MB250F-P0610-S12-01P	6	12	Profibus ×1	106.4	MB250F-P0610-S12-01E	6	12	EtherCAT ×1	106.4
MB250F-P1210-S06-01P	12	6	Profibus ×1	106.4	MB250F-P1210-S06-01E	12	6	EtherCAT ×1	106.4
MB250F-S24-01P	0	24	Profibus ×1	126.8	MB250F-S24-01E	0	24	EtherCAT ×1	126.8
MB250F-P1210-S12-01P	12	12	Profibus ×1	126.8	MB250F-P1210-S12-01E	12	12	EtherCAT ×1	126.8
MB250F-S30-01P	0	30	Profibus ×1	150.2	MB250F-S30-01E	0	30	EtherCAT ×1	150.2
MB250F-S36-01P	0	36	Profibus ×1	170.6	MB250F-S36-01E	0	36	EtherCAT ×1	170.6
MB250F-01C	0	0	CANBUS ×1	45.2	MB250F-01D	0	0	DeviceNET ×1	45.2
MB250F-P0610-01C	6	0	CANBUS ×1	65.6	MB250F-P0610-01D	6	0	DeviceNET ×1	65.6
MB250F-P1210-01C	12	0	CANBUS ×1	86	MB250F-P1210-01D	12	0	DeviceNET ×1	86
MB250F-P0610-S06-01C	6	6	CANBUS ×1	86	MB250F-P0610-S06-01D	6	6	DeviceNET ×1	86
MB250F-S12-01C	0	12	CANBUS ×1	86	MB250F-S12-01D	0	12	DeviceNET ×1	86
MB250F-P1810-01C	18	0	CANBUS ×1	106.4	MB250F-P1810-01D	18	0	DeviceNET ×1	106.4
MB250F-P0610-S12-01C	6	12	CANBUS ×1	106.4	MB250F-P0610-S12-01D	6	12	DeviceNET ×1	106.4
MB250F-P1210-S06-01C	12	6	CANBUS ×1	106.4	MB250F-P1210-S06-01D	12	6	DeviceNET ×1	106.4
MB250F-S24-01C	0	0	CANBUS ×1	126.8	MB250F-S24-01D	0	0	DeviceNET ×1	126.8
MB250F-P1210-S12-01C	12	12	CANBUS ×1	126.8	MB250F-P1210-S12-01D	12	12	DeviceNET ×1	126.8
MB250F-S30-01C	0	30	CANBUS ×1	150.2	MB250F-S30-01D	0	30	DeviceNET ×1	150.2
MB250F-S36-01C	0	36	CANBUS ×1	170.6	MB250F-S36-01D	0	36	DeviceNET ×1	170.6
MB250F-01N	0	0	CANOPEN ×1	45.2	MB250F-01F	0	0	ProfiNET ×1	45.2
MB250F-P0610-01N	6	0	CANOPEN ×1	65.6	MB250F-P0610-01F	6	0	ProfiNET ×1	65.6
MB250F-P1210-01N	12	0	CANOPEN ×1	86	MB250F-P1210-01F	12	0	ProfiNET ×1	86
MB250F-P0610-S06-01N	6	6	CANOPEN ×1	86	MB250F-P0610-S06-01F	6	6	ProfiNET ×1	86
MB250F-S12-01N	0	12	CANOPEN ×1	86	MB250F-S12-01F	0	12	ProfiNET ×1	86
MB250F-P1810-01N	18	0	CANOPEN ×1	106.4	MB250F-P1810-01F	18	0	ProfiNET ×1	106.4
MB250F-P0610-S12-01N	6	12	CANOPEN ×1	106.4	MB250F-P0610-S12-01F	6	12	ProfiNET ×1	106.4
MB250F-P1210-S06-01N	12	6	CANOPEN ×1	106.4	MB250F-P1210-S06-01F	12	6	ProfiNET ×1	106.4
MB250F-S24-01N	0	24	CANOPEN ×1	126.8	MB250F-S24-01F	0	24	ProfiNET ×1	126.8

MB250F-P1210-S12-01N	12	12	CANOPEN ×1	126.8	MB250F-P1210-S12-01F	12	12	ProfiNET×1	126.8
MB250F-S30-01N	0	30	CANOPEN ×1	150.2	MB250F-S30-01F	0	30	ProfiNET ×1	150.2
MB250F-S36-01N	0	36	CANOPEN ×1	170.6	MB250F-S36-01F	0	36	ProfiNET ×1	170.6
MB250F-01K	0	0	CC-LINK ×1	45.2	MB250F-P0610-S12-01K	6	12	CC-LINK ×1	106.4
MB250F-P0610-01K	6	0	CC-LINK×1	65.6	MB250F-P1210-S06-01K	12	6	CC-LINK ×1	106.4
MB250F-P1210-01K	12	0	CC-LINK ×1	86	MB250F-S24-01K	0	24	CC-LINK ×1	126.8
MB250F-P0610-S06-01K	6	6	CC-LINK ×1	86	MB250F-P1210-S12-01K	12	12	CC-LINK ×1	126.8
MB250F-S12-01K	0	12	CC-LINK ×1	86	MB250F-S30-01K	0	30	CC-LINK ×1	150.2
MB250F-P1810-01K	18	0	CC-LINK ×1	106.4	MB250F-S36-01K	0	36	CC-LINK ×1	170.6

Note: 1) N channels 10A rings parallel can be used as 1 channel N*10A current. For example: 2 rings 10A parallel could be used as 1 wires 20A

2) Power 10A and signal rings number can be with flexible module configuration on customer's request. Please contact customer service for more various industrial bus configuration.

Specifications

Mechanical Data		Electrical Data		
Parameter	Value	Parameter	Value	
Working Life	See product quality level table		Power	Signal
Rotating Speed	See product quality level table	Rated Voltage	0~440VAC/VDC	0~440VAC/VDC
Working Temperature	-30°C~80°C	Insulation Resistance	≥1000MΩ/500VDC	≥1000MΩ/500VDC
Operating Humidity	0~85% RH	Lead Wire	AWG16#Teflon	AWG22#Teflon or bus cable
Contact Material	See product quality level table	Lead Length	standard length 300mm (adjustable)	
Housing Material	aluminum alloy	Insulating Strength	500VAC@50Hz , 60s	
Torque	0.1N.m ; +0.03N.m/6 rings	Electrical Noise	<0.01Ω	
Protection Grade	IP51			

Product Quality Level Table

Quality Level Code	Max Rotating Speed	Working Life	Contact Material
VC (Common Version)	200RPM	15 Million Revs	Precious Metal
VD (Industrial Version)	600RPM	80 Million Revs	Gold-Gold
VH (high-end version)	1000RPM	150 Million Revs	Aluminum Alloy

Lead Wires Color Code

Ring	1	2	3	4	5	6	7	8	9	10	11	12
Color	BLK	RED	YEL	GRN	BLU	WHT	BLK	RED	YEL	GRN	BLU	WHT

(6 wires for 1 group colors, from 7-12, repeat the same color as 1...6, indicated with number code pipe.)

Options For Custom Slip Ring

Note: Below special demands can be customized. According, the delivery date will be extended 3 to 15 days; also the cost will be increased 30% to 50%. Most of our basic parts are standard and modular, which can save the cost and lead time.

- ① Flange size can be customized; cable exit way and cable length can be customized for both rotor and stator.
- ② Because of the structure limitation, length/height/OD can be customized on your request.
- ③ Support current or signal up to 200 rings.
- ④ Aviation plug, terminal and heat-shrink tube are optional.
- ⑤ Hybrid slip ring for Yaskawa/Panasonic/Siemens servo control signal, power line and encoder line.
- ⑥ Support mixed high speed data transmission (including Ethernet, USB, RS232, RS485, Profibus, CanBUS, CANOPEN, DeviceNET, CC-LINK, ProfiNET, EtherCAT, etc.)
- ⑦ Can combine temperature control signal with thermocouple signal.
- ⑧ Special environment can be customized, such as quakeproof, high temperature, etc.
- ⑨ Hybrid Pneumatic/hydraulic and electric slip ring can be mixed.
- ⑩ High temperature can up to 500 degrees.
- ⑪ High pressure can up to 110KV
- ⑫ Rotating speed can up to 10000RPM
- ⑬ Maximum current can up to 5000 amperes.
- ⑭ Military grade
- ⑮ Optional for underwater IP65, IP68.
- ⑯ Optional for stainless steel housing

Technical support: technical@moflon.com