

MFO200C series

2 Channels (FORJ)Fiber Optic Slip Rings

MFO200B fiber optic slip ring support 2 channels fiber optic(SM/MM). It can perfectly transmit data on 360° rotating. It is also especially suitable for occasion where it needs to transmit large volume data/signal from permanent position to rotation position under unlimited, continuous or discontinuous rotating, which can improve mechanical property, simplify system operation and avoid the rotating of turning joints destroying fiber optics.



Features :

- Low insertion loss, high rotation speed
- Non-contact, zero friction, long working life, single core can achieve one hundred million revolutions
- Small size, light weight, high sealing class
- Fiber optics transmitting signal, no leaks , no electromagnetic interference, long-distance transmission
- Loss below 1.5-2db can be customized

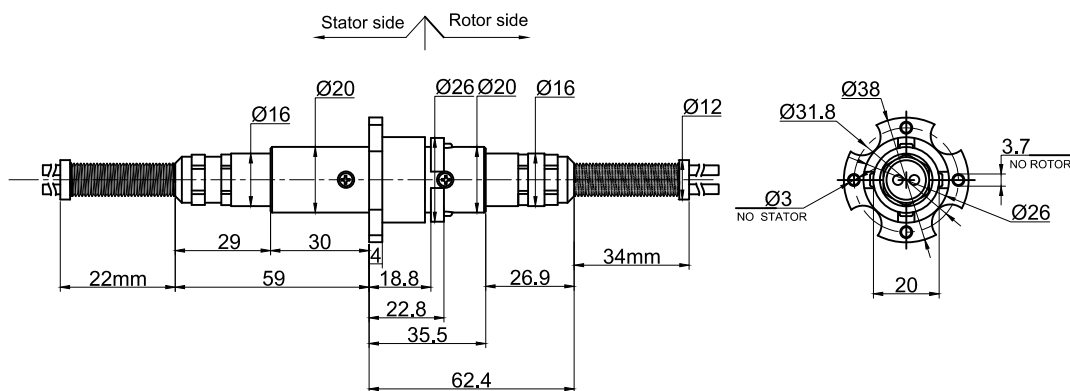

Part # Explanation

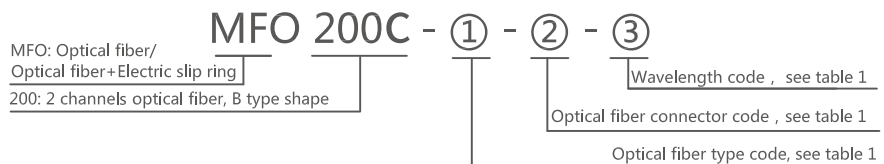

Table 1

Fiber Type Code	Fiber Connector Code	Wavelength Code
01 : 9/125um , Single-mode	FC : FC Connector ST : ST Connector	01 : 1310/1550(Single-mode)
02 : 50/125um , Multiple-mode	SC : SC Connector LC : LC Connector	02 : 850/1310(Multiple-mode)
03 : 62.5/125m , Multiple-mode	The connector face is PC by default , If APC is needed, APC shouldbe added behind APC, such as FC/APC.	

Specifications

Items	Type	Single-Mode	
		Single-Mode	Single-Mode
WaveWidth(nm)		±50	
Max insert Loss , 23°C(dB)	4		3.5
Insert Loss Ripple(dB)	2		1
Return Loss(dB)	≥55(APC)		≥40(PC)
Max Power(W)	0.5		
Weight(g)	200		
Max Rotating Speed(rpm)	250		
Working Life	>200 million turn		
Working Temperature(°C)	-45~85		
Storage Temperature(°C)	-50~85		
Protection Grade	IP68		